

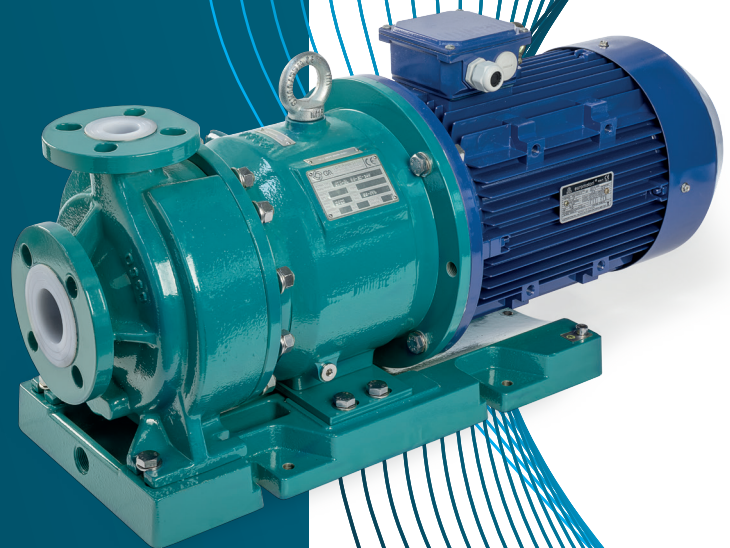

WE
PUMP
YOUR
CHEMICALS



XTN SERIES

LINED - MAGNETIC DRIVE
CENTRIFUGAL PUMPS
WITH OPEN IMPELLER

XTN-BL

Close coupled with B5 motors

Range of applications

- _ Fine Chemical Services
- _ Basic Chemical Services
- _ Pharmaceutical industries (API)
- _ Transfer of reactor process solutions

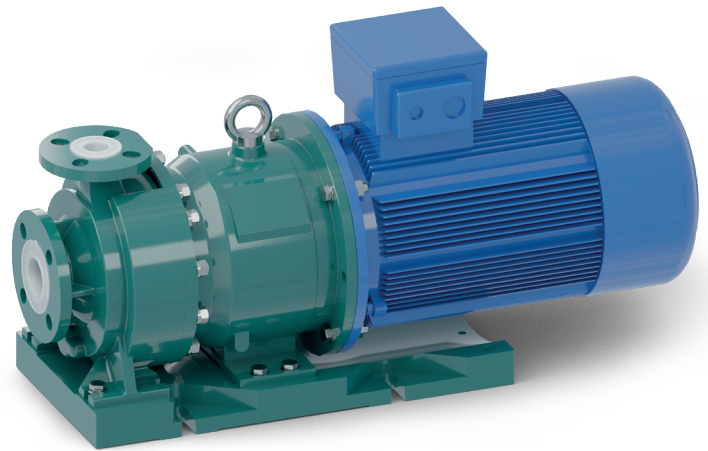

in compliance with:
2006/42/CE



ATEX 100
Directive: 2014/34/EU



Mag drive concept

The synchronous drive configuration is based on an outer magnet ring assembly built to magnetically couple with an inner magnet ring assembly. These two magnet rings are locked together by the flux of attracting magnet poles flowing through the containment isolation shell.

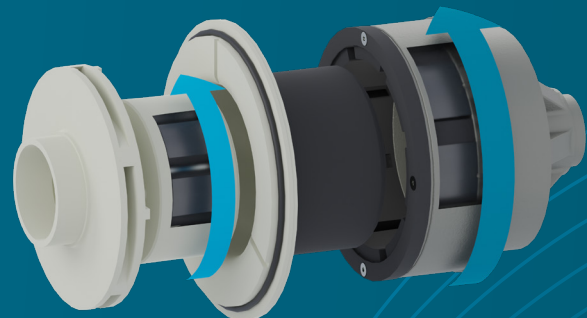

'X' series a solution for solids in suspension

Zero emissions due to the magnetic drive design.
Reduced maintenance costs: no double mechanical seals and external flushing system which, in case of failure, can contaminate the process liquid with the external fluid.

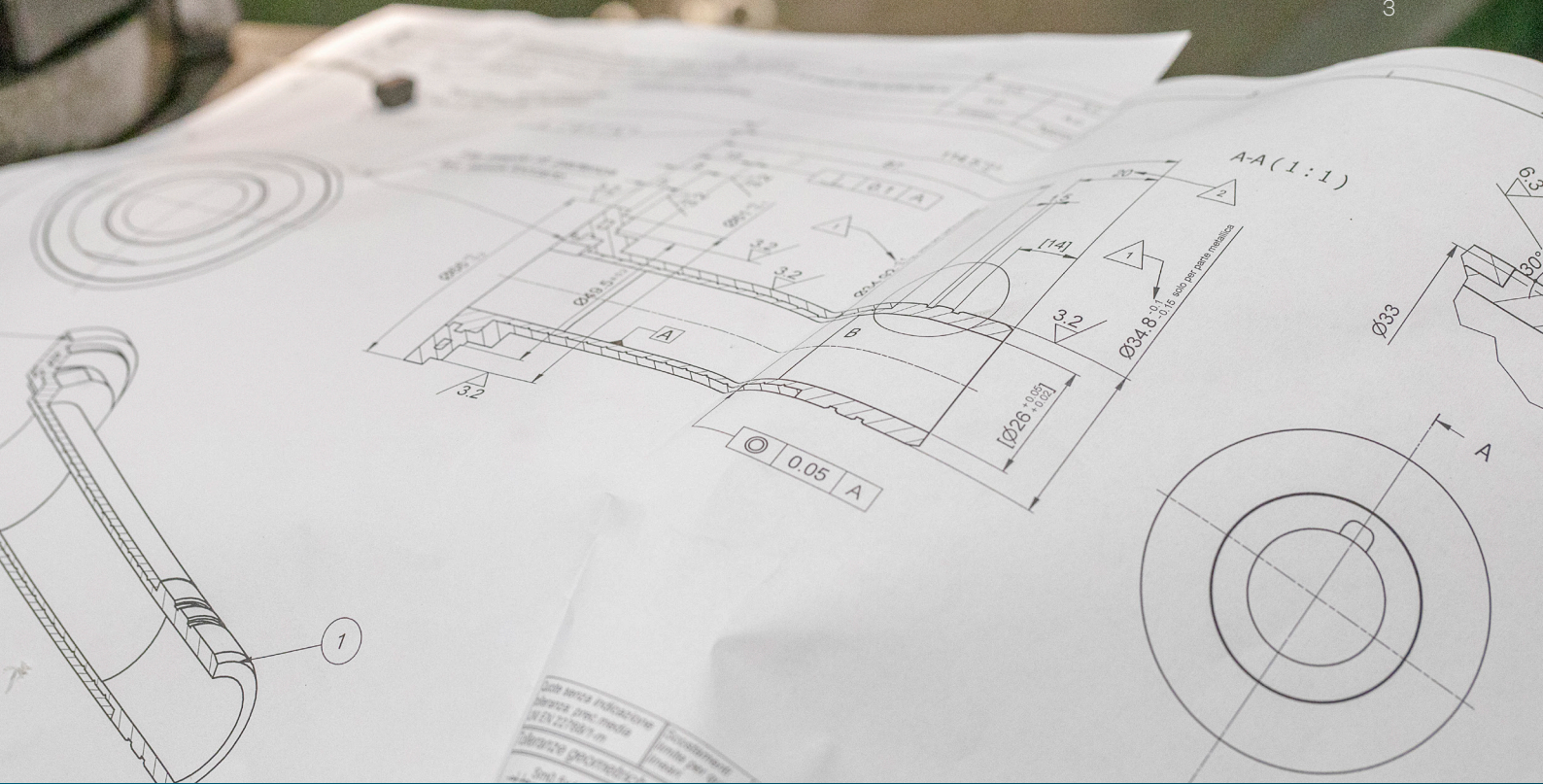

R&D with Fluidodynamic Simulation

Designed with an innovative simulation software, that permits to obtain high hydraulic performances and efficiency levels near to the physical possible values.

Simulated with **Ansys**

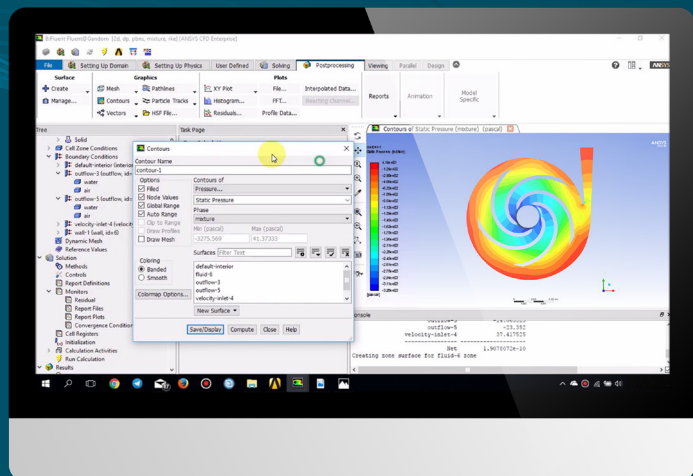

*All Ansys, Inc. brand, product, logos are registered trademarks or trademarks of Ansys, Inc.

XTN Serie Main features and 3d view

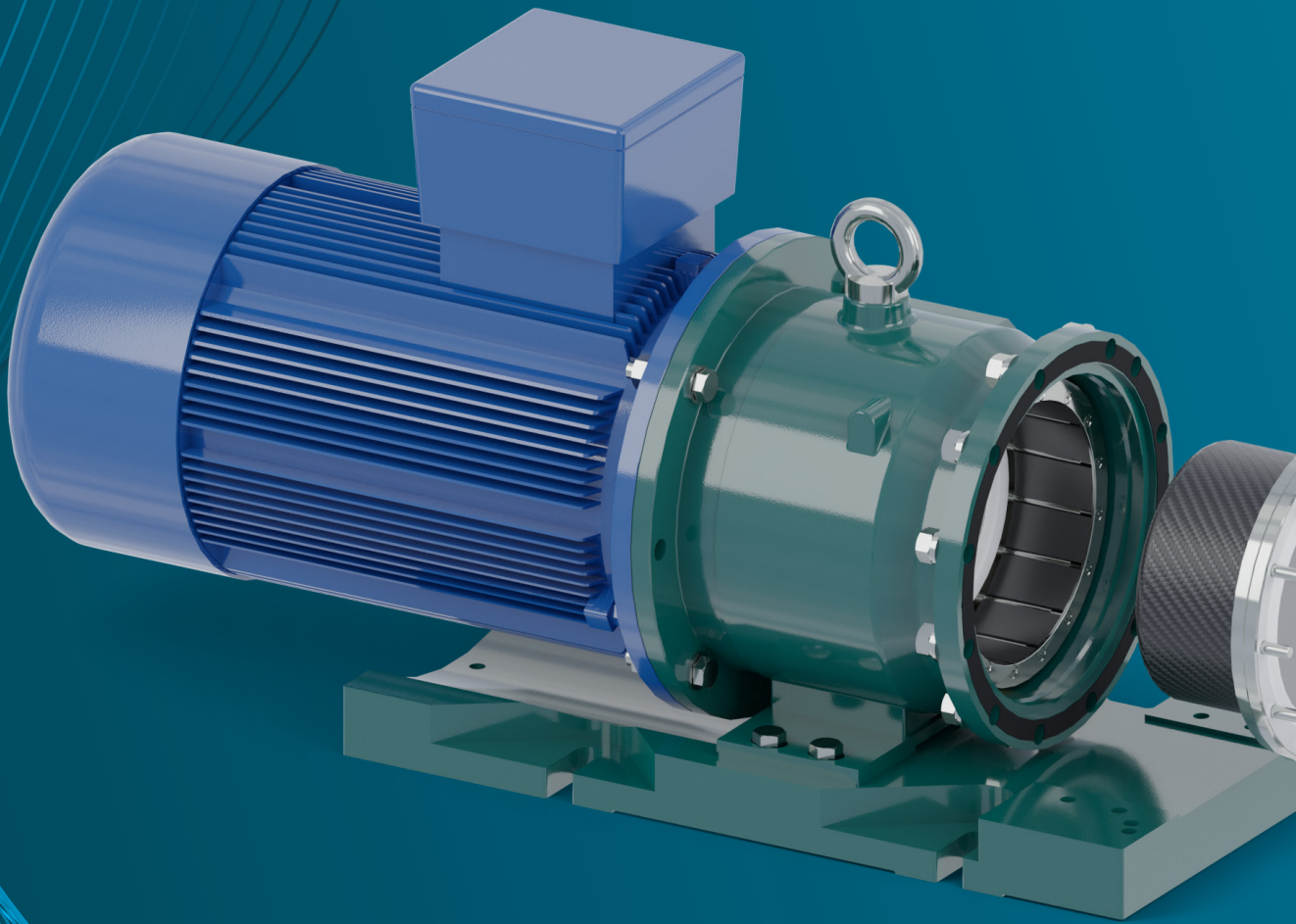

01. Isolation shell

Made of 2-pieces composite material. PFA in contact with the fluid and external carbon fiber reinforcement to guarantee the right mechanical resistance.

02. Internal magnet

Fully coated magnetic core. It is coupled to the impeller by a shaft with a locking system with key, nut and washer.

03. Bushes

Made of diamond coated silicon carbide (RSSiC), they have generous passage channels to ensure optimal circulation of liquid and solid particles. The diamond coating protects the bushes in case of poor lubrication or accidental dry running.

04. Open impeller

The star configuration guarantees the centrifugation of suspended solids and allows the reduction of the axial thrusts that stress the bushes.

05. Casing

Pump casing, internal magnet assembly and impeller are made by transfer moulding. All parts in contact with the pumped product are lined in PFA guaranteeing a lining thickness equal to 4 mm of fluoropolymer.

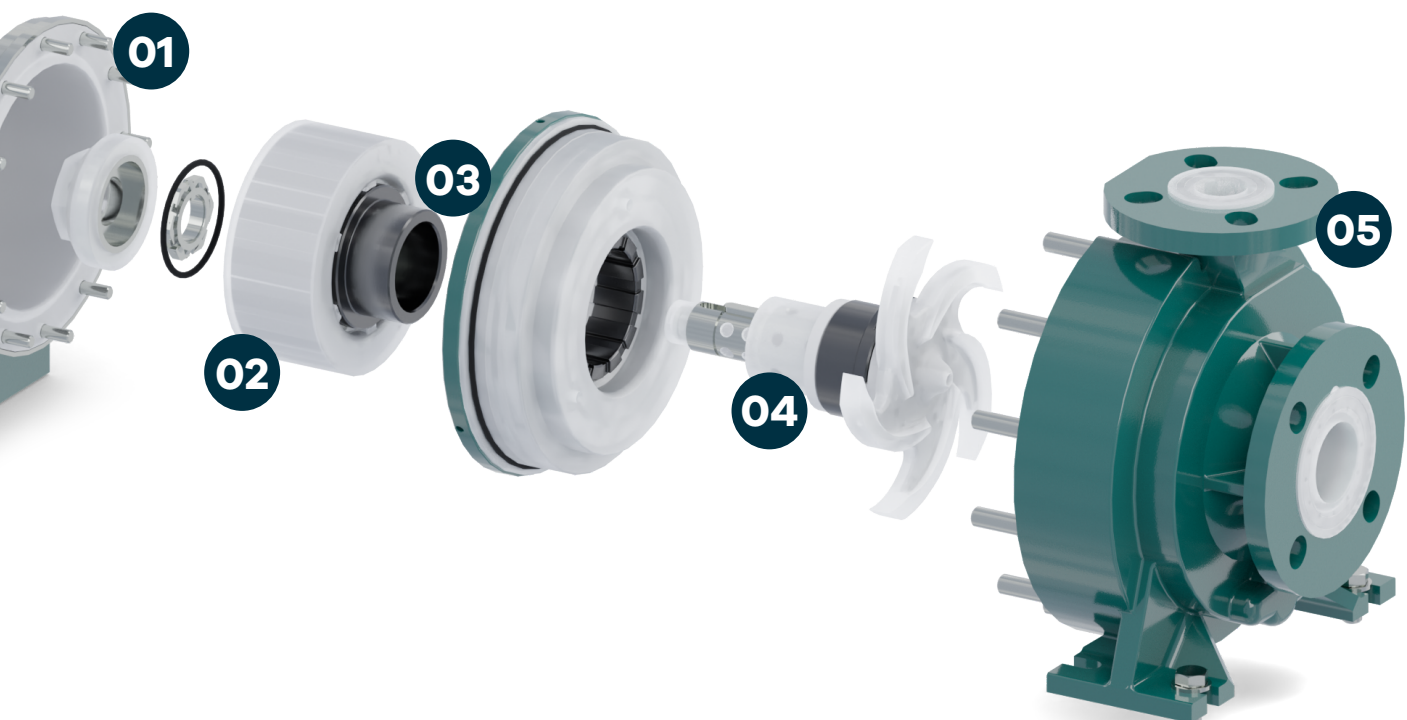

Internal circulation of liquid and solid particles

In the fully lined or stainless steel CDR pumps of the "X" series, the circulation of the fluid loaded with solid particles is guaranteed by the large flow channels inside the pump. In this way the bushes and the isolation shell are correctly cooled.

The axial flushing hole of the impeller shaft also ensures a continuous exchange of liquid pumped between the shell and the volute.

ROTATING SHAFT

integrated inside the impeller, it boasts a total absence of welding or joints. A stainless steel core is lined with PFA. No risk of seepage in the case of incorrect direction of rotation.



WATCH THE VIDEO OF THE "X" SERIES PUMPS FOR THE TREATMENT OF LIQUIDS WITH SUSPENDED SOLIDS.

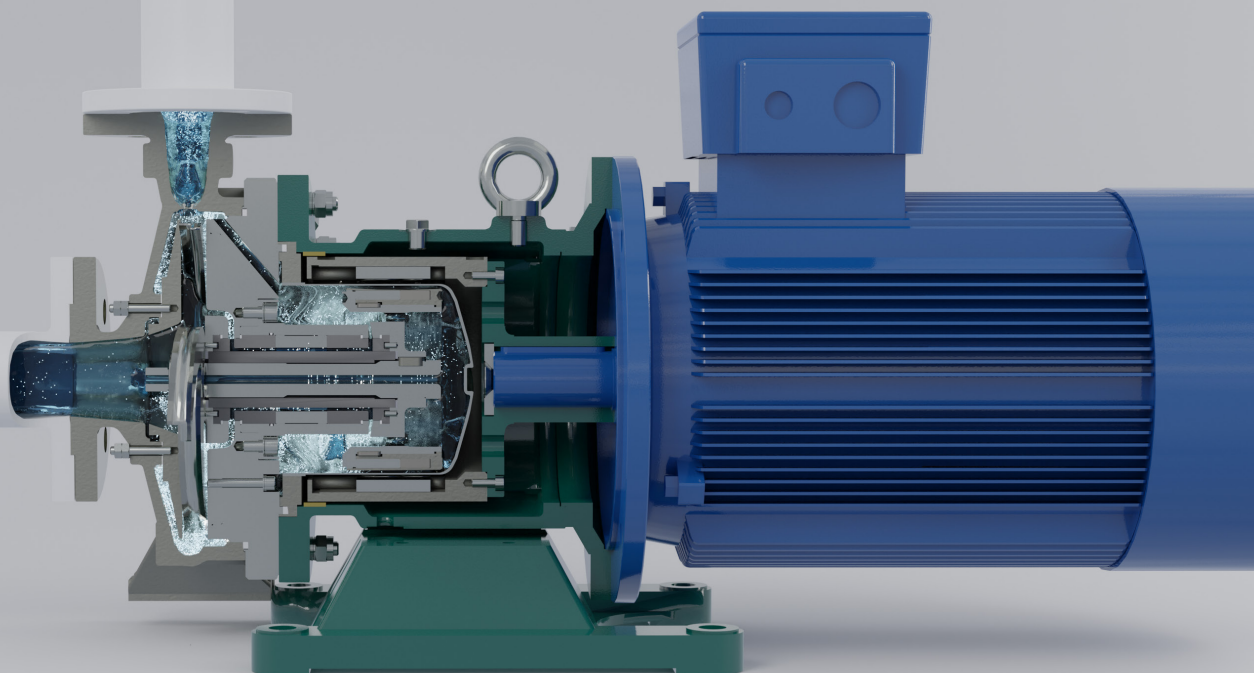

Diamond coated SIC bushes



X Series pumps are provided with diamond coated SIC bushes kit as a standard, to prevent poor lubrication conditions, that may happen whenever solid particles concentration increases abnormally. The carbon surface coating guarantees a reduction in the friction coefficient of approximately 80% (0.04 urs of RSSiC instead of 0.4 - 0.7 urs of SiC).

Other critical working conditions in which RSSiC increases the reliability of the pump as well as durability over time:

- _ Pumping of low-boiling liquids
- _ Work at low flow rates. In these conditions the heat generated by the magnetic coupling is not completely dissipated by the process fluid
- _ Work at high flow rates (above the BEP). In these conditions, both the risk of cavitation and the risk, due to the low pressure of the delivery fluid, of incorrect heat dissipation in the rear area of the isolation shell simultaneously increase.

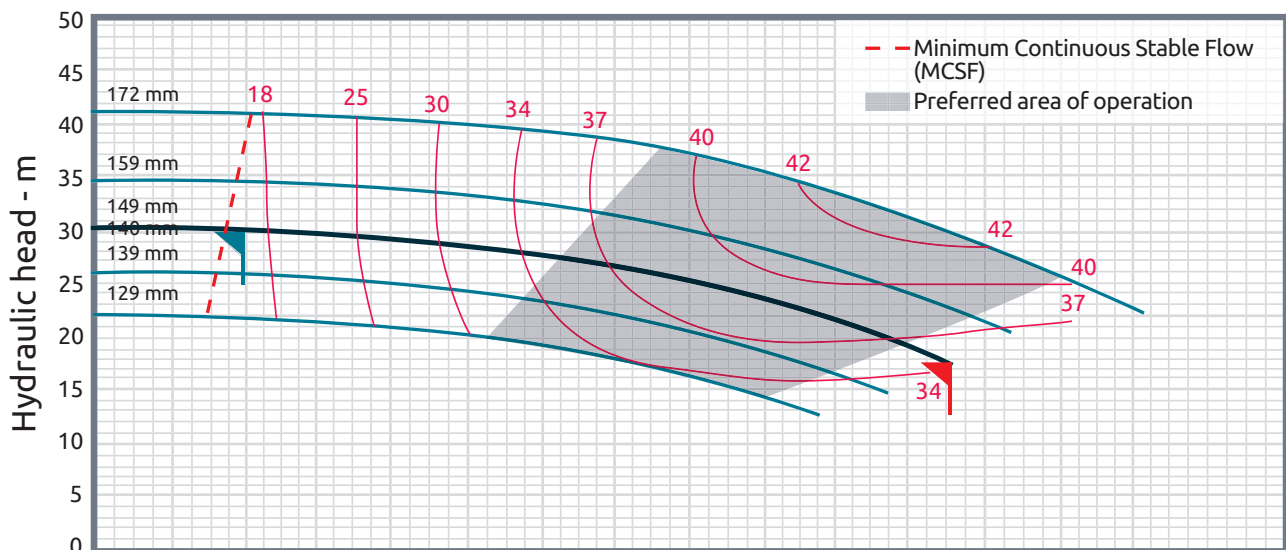

Performance Curves

50 Hz

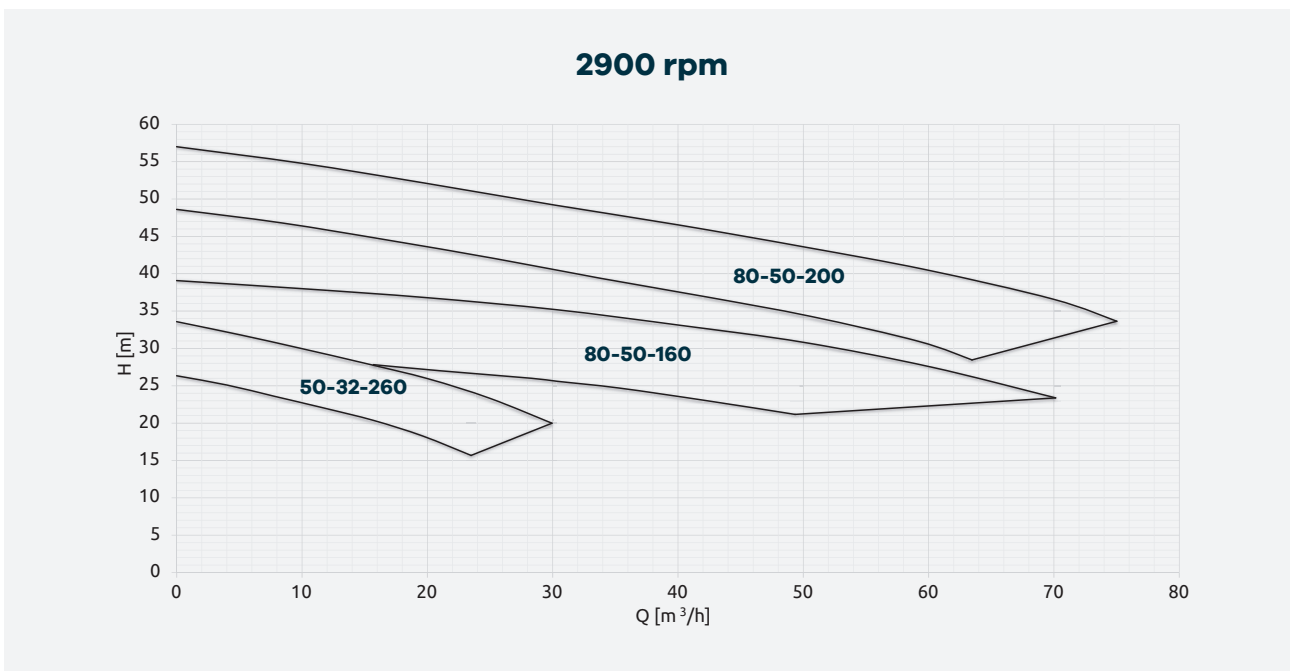
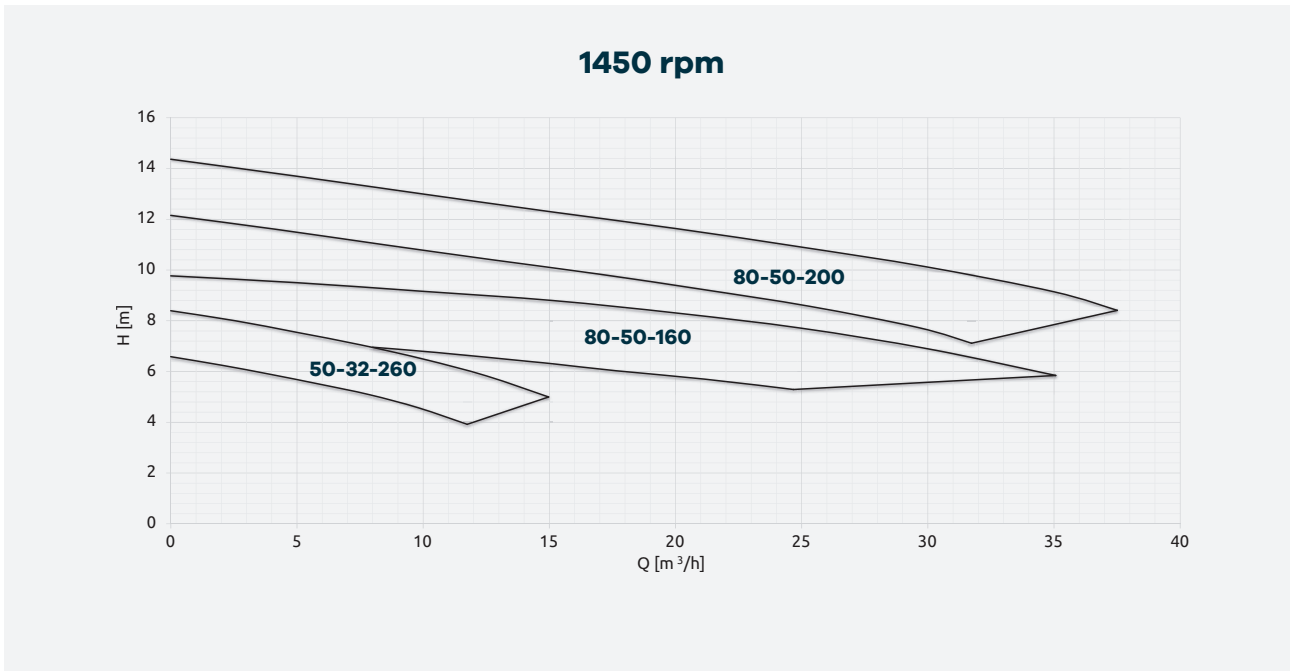

Not binding data refers to water at room temperature.
For specific performance curve contact CDR Pompe S.R.L.

60 Hz

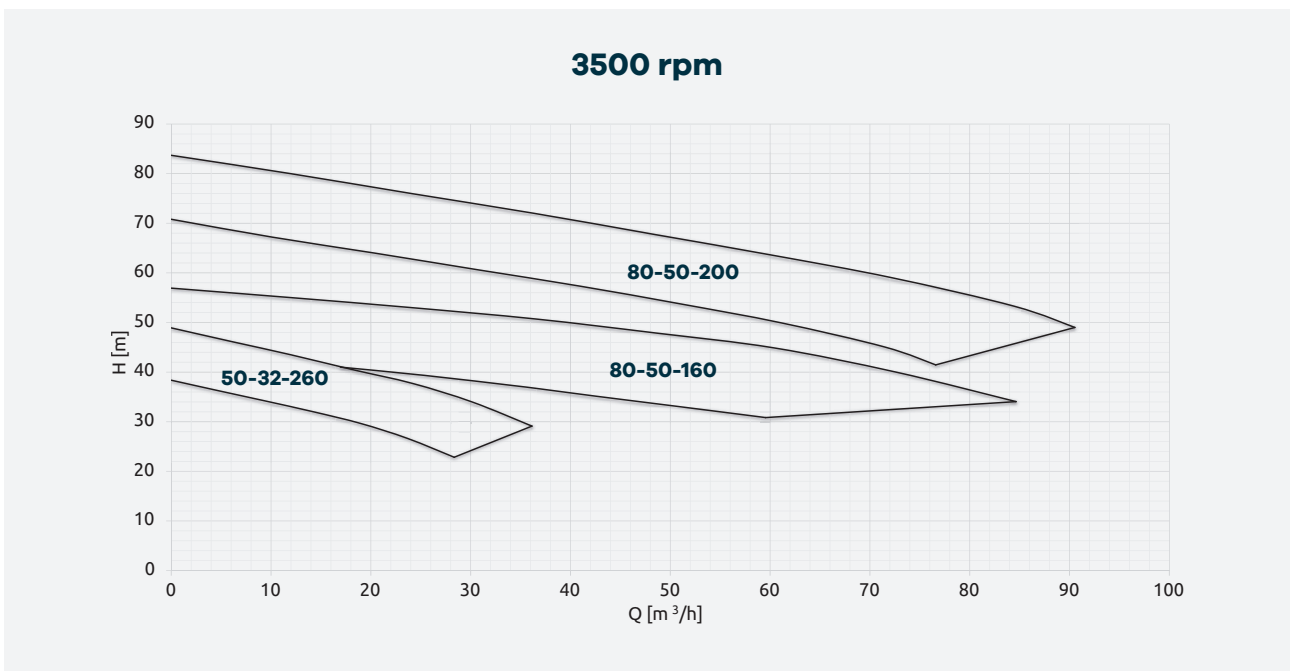
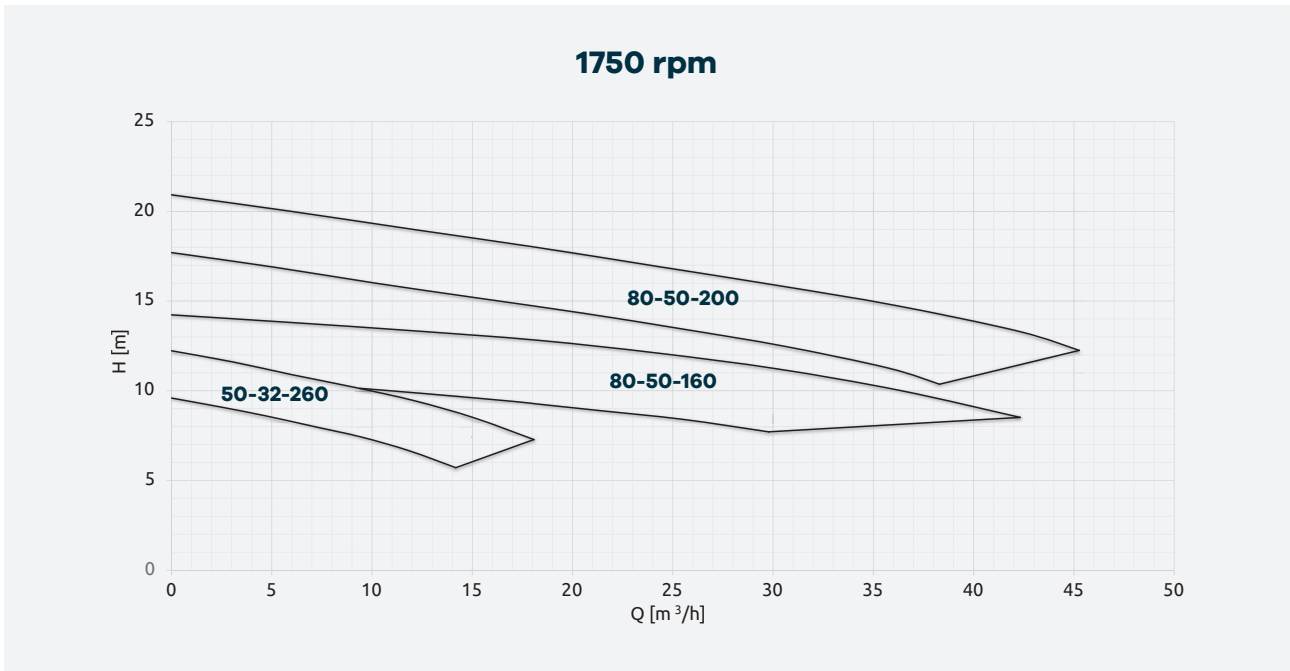

XTN-BL

Section drawings

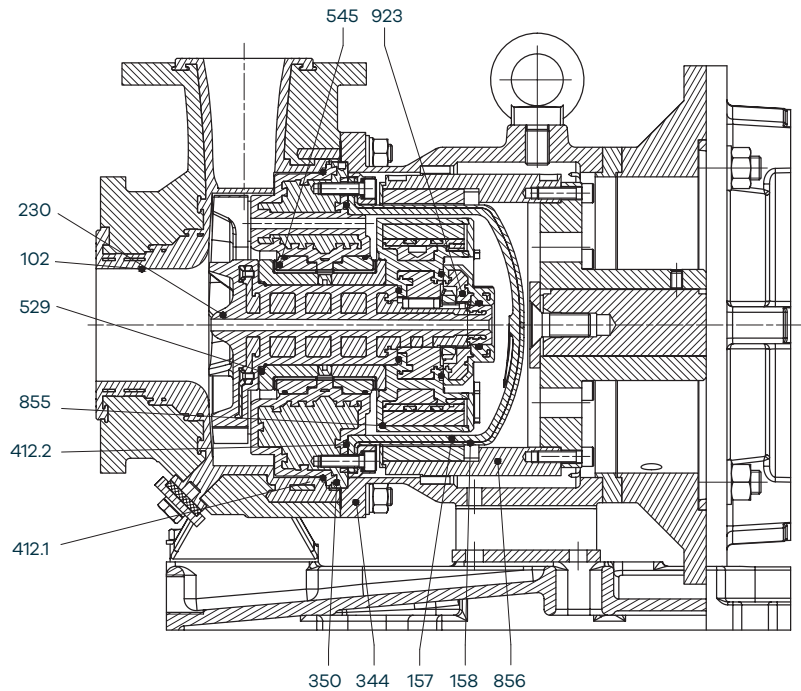

Technical specifications

Performance at 2900 rpm

Q max = 70 m³/h
H max = 60 mcl

Motors

0.75 kW (motor size 80)
18,5 kW (motor size 160)

Allowable temperatures

- 50 °C / + 160 °C

Allowable pressures

PN16 (20 °C)

Sizes

50-32-160 : DN50/DN32
80-50-160 : DN80/DN50
80-50-200 : DN80/DN50

Flanging

UNI 1092-2 / ISO 7005-2 PN 16, type B
slotted ASME / ANSI class 150

Viscosity

min: 0,5 cSt
max: 180 cSt

Allowable solids

Consult CDR pumps

Internal components

DIN	Components	Materials
102	Casing	PFA lined
157	Isolation shell	PFA
158	Shell Reinforcement	Carbon Fiber
230	Impeller	PFA lined
344	Lantern	EN-GJS-400-15
350	Bush Support	PFA lined
412.x	O-Ring	FPM / FEP
529	Rotating bush	Run Safe Sintered SSIC
545	Static bush	Run Safe Sintered SSIC
855	Internal magnet	PFA Lined / NdFeB
856	External magnet	EN-GJS-400-15 / Ryton / NdFeB
923	Fixing ring	PFA

XTN-BL

Overall dimensions

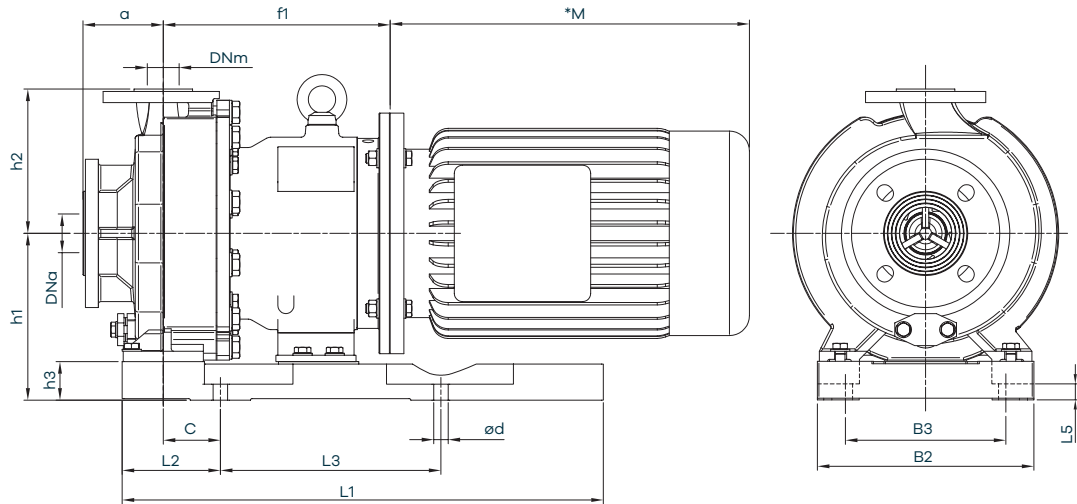

Pump dimensions

Model	XTN-BL 50-32-160	XTN-BL 80-50-160	XTN-BL 80-50-200
DNa	50	80	80
	UNI EN 1092-1 PN 16RF slotted ANSI 150		
DNm	32	50	50
	UNI EN 1092-1 PN 16RF slotted ANSI 150		
a (mm)	80	100	100
h2 (mm)	160	180	200
h3 (mm)	48	48	48
L2 (mm)	550	550	550
L2 (mm)	122,5	122,5	122,5
L3 (mm)	275	275	275
L5 (mm)	20	20	20
B2 (mm)	270	270	270
B3 (mm)	200	200	200
c (mm)	70	70	70
$\varnothing d$ (mm)	18	18	18

Base dimensions

Motor dimensions	XTN-BL 50-32-160	XTN-BL 80-50-160	XTN-BL 80-50-200
90 (mm)	257	257	257
100 (mm)	257	257	257
f1			
112 (mm)	257	257	257
132 (mm)	287	287	287
160 (mm)	302	302	302
h1			
90 (mm)	180	208	208
100 (mm)	180	208	208
112 (mm)	180	208	208
132 (mm)	180	208	208
160 (mm)	208	208	208
Motor shape	B5	B5	B5
Pump weight (without motor)	83	100	115

*The M dimension depends on the motor installed



CDR Pompe

Via Raffaello Sanzio, 57
20021 Bollate (MI)
Tel. +39 02 9901941

www.cdrpompe.com

Technical characteristics:

The data and technical characteristics shown in the General Catalogue are not binding. CDR Pompe SRL reserves the right to implement changes without notice. Therefore the data, the size, performance and any other information reported are indicative and not binding. For any technical details you can request the product update form.